

EXCELLENCE
FOR
YACHTS

EXCELLENCE IN PROJECTS AND IN YACHTING SERVICES

TDM SRL WAS BORN FROM THE LONG EXPERIENCE OF OUR COLLABORATORS
COMBINED WITH THE YOUNG MANAGEMENT CAPABLE
OF DELIVERING A RESULT

- 3D DIGITAL SURVEY
- DESIGN AND RENDERING
- TEAK DECKING
- CUSTOM COMPONENTS

EACH OF OUR PROJECTS IS STUDIED AND ENGINEERED.
ONLY AFTER APPROVAL IS MADE BY CNC MACHINERY.
THE ASSEMBLY AND INSTALLATION ARE CARRIED OUT EXCLUSIVELY
BY OUR MONODOPERA, CAREFULLY SELECTED AND FORMED.



TEAK DECKING



VASCA IDROMASSAGGIO - JACUZZI



CUPRAILS - CAPODIBANDA

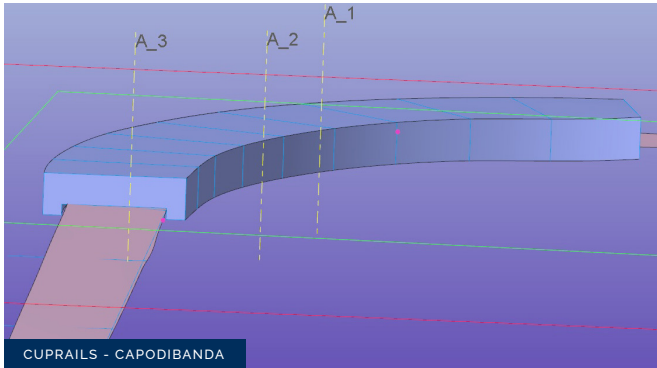

CUPRAILS - CAPODIBANDA

TECHNOLOGY SPECIALIZATION WISE CRAFTSMANSHIP

THE GREAT ATTENTION TO DETAIL BEGINS WITH
CAREFUL TECHNICAL RELIEFS, WITH ACCURATE
ENGINEERING AND DESIGN, TO ACHIEVE TAILOR MADE
RESULTS OF EXCELLENCE

EXTERNAL LADDERS - TYPICAL SECTION

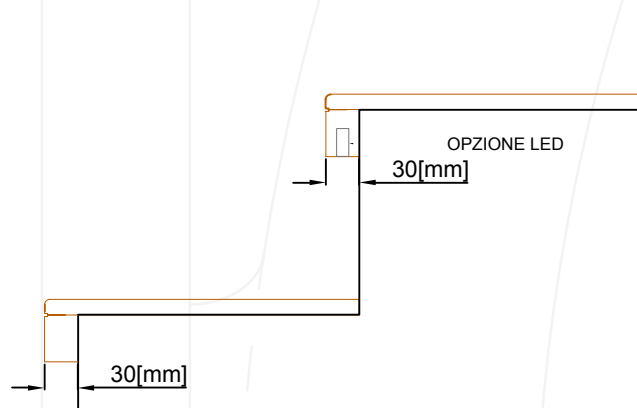

CLASSIC CARABOTTINO AND TAILOR MADE

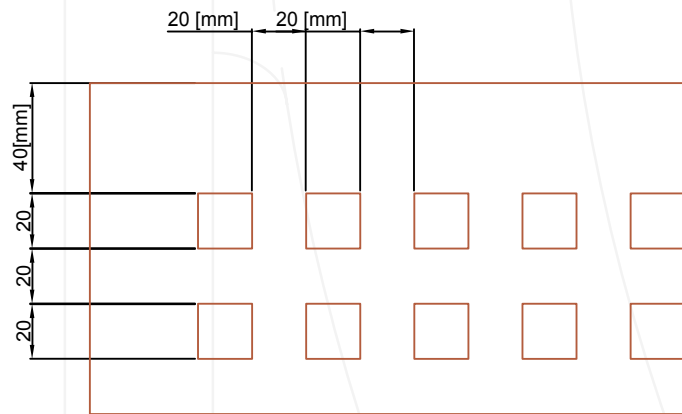



TECHNICAL SPECIFICATION

EXAMPLE OF OUR TECHNICAL SPECIFICATION

DEFINITION OF THE HEADING SLATS CENTRE SHIP

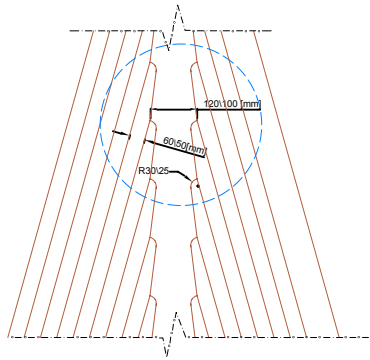

DEFINITION OF SHAPE IN CASE OF INTERSECTION BETWEEN CURVED SLATS AND MASTS

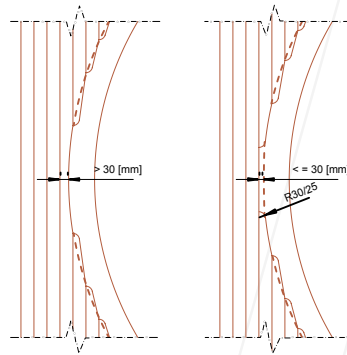

EXTERNAL LADDERS- TYPICAL PLANT 1 & 2

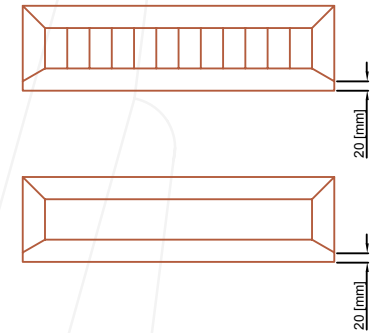

STANDARD TYPE OF SLATS - TYPICAL SECTION

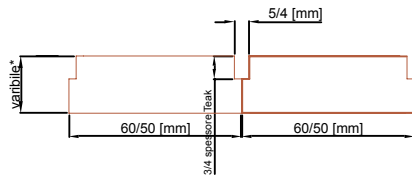

DEFINITION OF SHAPE IN THE CASE OF HEADING BETWEEN THE PLANKS AND THE BOAT CENTER MASTS

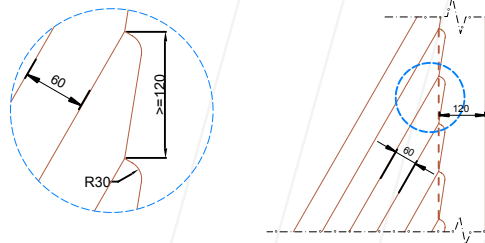

DEFINITION OF SHAPE IN THE CASE OF HEADING BETWEEN THE PLANKS AND THE MASTS

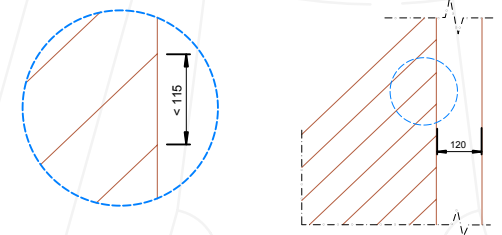

STANDARD TYPE OF MAST - TYPICAL SECTION

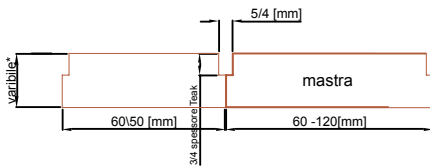

*VARIABLE DEPENDING ON THE CUSTOMER

TDM SRL

+39 3806342946

INFO@TDM SRL.IT

REGISTERED OFFICE

LERICI (SP)

C.F. - P.IVA 01570660116

WWW.TDM SRL.IT